

92 COMPRESSION LOAD CELL

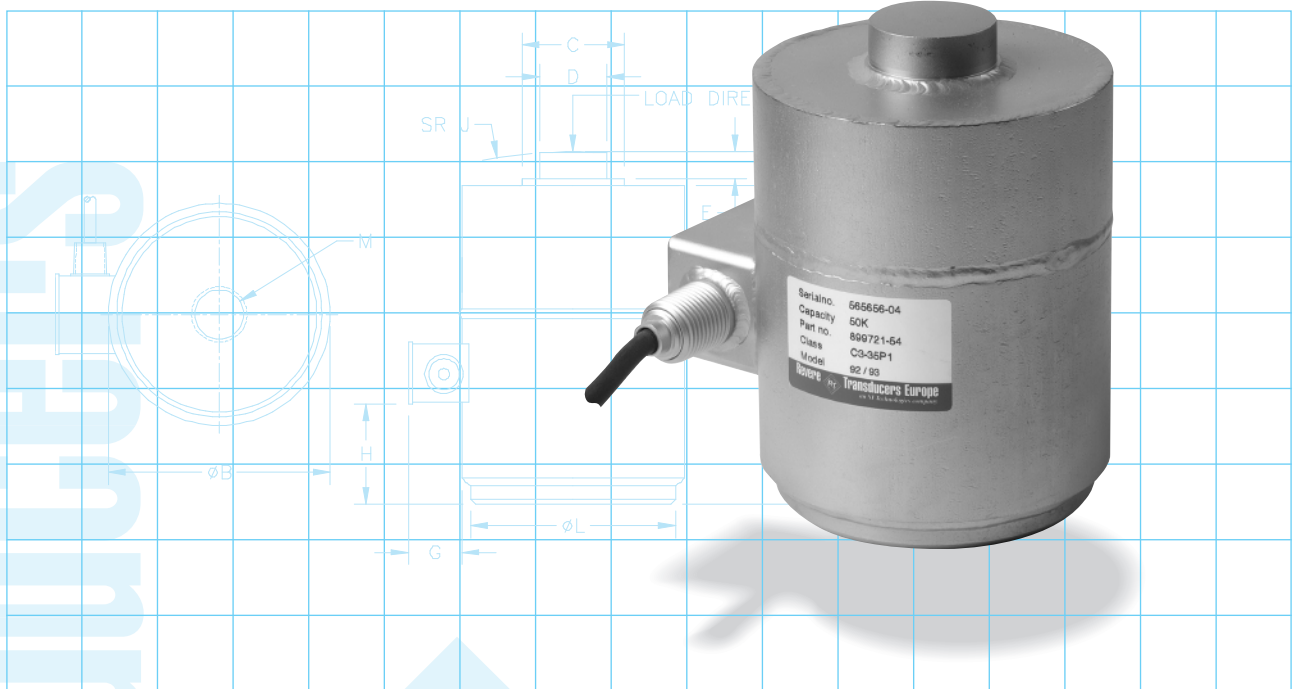

FEATURES:

- Capacities: 5 to 200 K lbs
- Environmental protection: IP68 (DIN 40.050)
- Material: Stainless steel
- Hermetically sealed

DESCRIPTION:

The 92 canister is designed for compression applications. Its stainless steel construction combined with hermetically sealing allows the 92 to be used in harsh environments.

A large range of capacities is available.

Hermetic sealing offers excellent protection from moisture and provides long-term stability and reliability.

APPLICATIONS:

- Silos, Tanks and Hoppers
- Suspended Silos, Tanks and Hoppers
- Railroad Scales
- Weighbridges

APPROVALS:

92: SPECIFICATIONS

Parameter	Symbol	Unit of Measure	Specification
			Imperial
Capacities	E_{max}	lb	5K, 10K, 20K, 25K, 50K, 100K, 150K, 200K
Accuracy Class			D3
Accuracy Class According to			Non-NTEP
Potentially Explosive Atmospheres options			Not Available
Maximum number of Verification Intervals	n_{ic}		
Minimum Verification Interval	V_{min}		
Combined Error ¹	n	±%S	0.05
Creep error (20 minutes)		±%S	0.03
Temperature Effect on Zero	TC_0	±%FS/5°C (°F)	0.0090 (0.0010)
Temperature Effect on Output	TC_S	±%S/5°C (°F)	0.0135 (0.0015)
Rated Output	FS	mV/V	2 ± 0.002
Compensated Temperature Range	T_{cps}	°C (°F)	-10 to +40 (+14 to +104)
Operating Temperature Range	T_{opr}	°C (°F)	-53 to +93 (-65 to +200)
Environmental Protection			IP68
Cable Length		m (ft)	12,2 (40)
Cable Type			4 Wire shielded, Shield is not connected to load cell body
Zero Balance		±%FS	1.0
Safe Load Limit	E_{lim}	% E_{max}	150
Ultimate Load	E_{ult}	% E_{max}	200
Safe Side Load Limit		% E_{max}	10
Excitation Voltage		Volts AC or DC	10 Recommended, 15 Maximum
Input Resistance		Ohms	350.0 ± 3.5
Output Resistance		Ohms	350.0 ± 3.5
Insulation Resistance at 50 VDC		Mega Ohms	>5000
Element Material		ASTM	Stainless steel

Notes:

- We continually improve our products and therefore specifications are subject to change without notice.
- The accuracy may be affected if 4-wire load cell cables are shortened.

[1] Includes the effects of Non-Linearity and Hysteresis.

Wiring color code:

Excitation +	Red
Excitation -	Black
Output +	Green
Output -	White
Shield	Transparent

Capacity	Dimensions in inches				
	5-15K	20,25K	50 K	100K	150-200K
A	4.00	5.00	6.00	8.50	11.03
B	3.53	3.53	4.25	5.03	6.53
C	1.25	1.25	1.63	2.45	2.97
D	1.00	1.00	1.50	1.75	2.50
E	0.10	0.10	0.10	0.10	0.10
F	0.40	0.40	0.50	0.63	0.63
G	1.15	1.15	1.18	1.25	1.36
H	0.61	0.89	1.49	2.90	4.19
M UNF deep	1/2-20 0.50	1/2-20 0.40	3/4-16 0.56	3/4-16 0.56	3/4-16 0.56
J	6.00	6.00	6.00	12.00	12.00

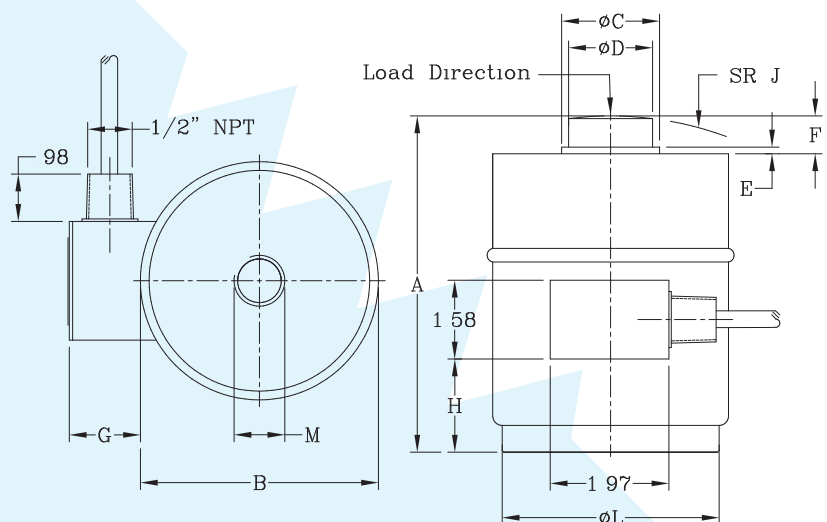

Attention: All dimension tolerances according to ISO 2768m, unless otherwise specified.

Mounting:

Correct mounting of the load cells is essential to ensure optimum accuracy and performance. Further information is available on request.

No Mounts available for 92.

REVERE TRANSDUCERS EUROPE
 Ramshoorn 7
 4824 AG Breda
 The Netherlands
 Tel.: (+11) 76 5412854
 Fax: (+31) 76 5480700
 E-mail: info@revere.nl
 www.revere.nl

REVERE TRANSDUCERS INC.
 14192 Franklin Avenue
 Tustin, CA 92780-7016
 U.S.A.
 Tel.: (+1) 714.731.1234
 Fax: (+1) 714.731.2019
 E-mail: info@reveretransducers.com
 www.reveretransducers.com