



Prüfschein

Test certificate

Ausgestellt für:
Issued to: Revere-Transducers Europe BV
Ramshoorn 7
NI - 4824 AG Breda
Netherlands

Prüfgrundlage:
In accordance with: EN 45501 (1992), para. 8.1 & 3.5.4 mit Fehleranteil / *with fraction* $p_{LC} = 0,7$
OIML R60 (1991), WELMEC 2.4

Gegenstand:
In respect of DMS-Druckwägezellen / *strain gauge compression load cells*
Typ / *type* RLC ..
E_{max} 60 kg ÷ 60 t
Genauigkeitsklasse / *accuracy class* C1 ÷ C6, C3 MI 7,5

Kennnummer: ---
Serial number:

Prüfscheinnummer: **D09-97.18** Rev. 2
Test certificate number:

Datum der Prüfung: ---
Date of Test:

Anzahl der Seiten: 5
Number of pages:

Geschäftszeichen: 1.14 - 99024730
Reference No.:

Benannte Stelle 102
Notified Body

Im Auftrag
By order

Dr. Meißner



Braunschweig, 07.04.2000

Siegel
Seal

Anlage zum Prüfschein

Annex to test certificate

vom 07.04.2000, Prüfscheinnummer: D09-97.18 Rev. 2
dated 07.04.2000, test certificate number: D09-97.18 Rev. 2

Seite 2 von 5 Seiten
Page 2 of 5 pages

1. Technical data

The metrological characteristics of the load cells are shown in Table 1, further technical data are given in the data sheet of the manufacturer on pages 4 and 5 of this annex.

Table 1: Essential characteristics

Accuracy class	³⁾	C1	C2	C3	C3 MI 6	C3 MI 7,5	C4	C5	C6
Max. number of load cell intervals	n_{LC}	1000	2000	3000	3000	3000	4000	5000	6000
Maximum capacities	E_{max}	0,06 / 0,13 / 0,25 / 0,5 / 1 / 2 / 3,5 t 5 / 10 / 13 / 28 / 60 t			0,06 t ÷ 10 t		0,5 t ¹⁾ 1 t ÷ 5 t		
Minimum LC verification interval	$v_{min} (Y)$	$E_{max} / 5000$	$E_{max} / 7500$	$E_{max} / 10000$	$E_{max} / 10000$	$E_{max} / 10000$	$E_{max} / 10000$	$E_{max} / 15000$	$E_{max} / 15000$
Minimum LC verification interval type MR	$v_{min} MR (Y_{MR})$	$E_{max} / 10000$	$E_{max} / 15000$	$E_{max} / 20000$ ²⁾	$E_{max} / 20000$	$E_{max} / 20000$	$E_{max} / 20000$	$E_{max} / 25000$	$E_{max} / 28000$
Minimum dead load output return	$DR (Z)$	--	--	--	$\frac{1}{2} E_{max} / 6000$	$\frac{1}{2} E_{max} / 7500$	--	--	--

Minimum dead load: $0\% \cdot E_{max}$ (4% für $E_{max} = 0,25t$); Save load: $\sim 150\% \cdot E_{max}$; Input resistance: $\sim 1,1k\Omega$

¹⁾ Maximal application range: $0,75 \cdot E_{max}$, ²⁾ For 28 and 60t: $Y = 15000$, ³⁾ Additional classification see EN 45501 Nr. 4.12.2

2. Tests

Base of this test certificate are the PTB certificates D09-97.18 of 01.08.97, D09-97.18 Rev.1 of 30.10.98, 1.13-93.099 of 25.06.93 and 1.13-92.410 of 06.06.94.

At the PTB the determination of load cell error, repeatability error, temperature effect on minimum dead load output, creep and minimum dead load output return in the temperature range of $-10^{\circ}C$ to $+40^{\circ}C$ according OIML R60 have been performed on following patterns:

C3 MR, $E_{max} = 0,25t$, No. 274312-98 and C3 MI 7,5 MR, $E_{max} = 10t$, No. 286585;
the humidity test and the influence of barometric pressure according to OIML R60 (1991) have been applied to the first pattern and pattern C4, $E_{max} = 60kg$, SN 303054-99.

With the agreement of the PTB and in presence of PTB staff at the manufacturers testing site, the following patterns have been tested:

accuracy class C4MR und C3 MI 7,5 MR, capacities
 $E_{max} = 60kg$ / No. GB0004B & 5B, $E_{max} = 130kg$, No GC0005B & 6B and
accuracy class C 6 MR und C 3 MI 7,5 MR, capacities
 $E_{max} = 0,5t$ / No. 430063, $E_{max} = 1t$ / No. 121533 and $E_{max} = 2t$ / No. 210038 and
accuracy class C3, capacity $E_{max} = 28t$ / No. 04.

Table 2: Tests

Test	R60 Nr :	Institute		Result
Temperature test and repeatability (at 20, 40, -10, and 20°C)	15.1 & 5.1 & 9.0	PTB	Manufacturer	+
Temperature effect on minimum dead load output (at 20, 40, -10, and 20°C)	15.1 & 10.1.3	PTB	Manufacturer	+
Creep test (at 20, 40 and, -10°C)	15.2 & 7.1	PTB	Manufacturer	+
Minimum dead load output return (at 20, 40 and, -10°C)	15.3 & 7.2	PTB	Manufacturer	+
Barometric pressure effects at room temperature	15.4 & 10.2	PTB	+	+
Humidity test	15.5 & 7.3	PTB	Manufacturer	+

The test results of the manufacturer are in accordance with the test results obtained at the PTB.

Physikalisch-Technische Bundesanstalt

Anlage zum Prüfschein

Annex to test certificate

vom 07.04.2000, Prüfscheinnummer: D09-97.18 Rev. 2

dated 07.04.2000, test certificate number: D09-97.18 Rev. 2

Seite 3 von 5 Seiten

Page 3 of 5 pages

3. Description of the load cell

The load cells of RLC type are bending ring load cells. Forces are applied perpendicular and in opposite direction to both bounding circles of a ring. This results in a tangential straining of the surface of the ring. This strain is measured by ring shaped strain gauges.

The load cells are made of stainless steel, the strain gauge application is hermetically encapsulated and filled with inert gas.

Further essential data is presented in the data sheet.

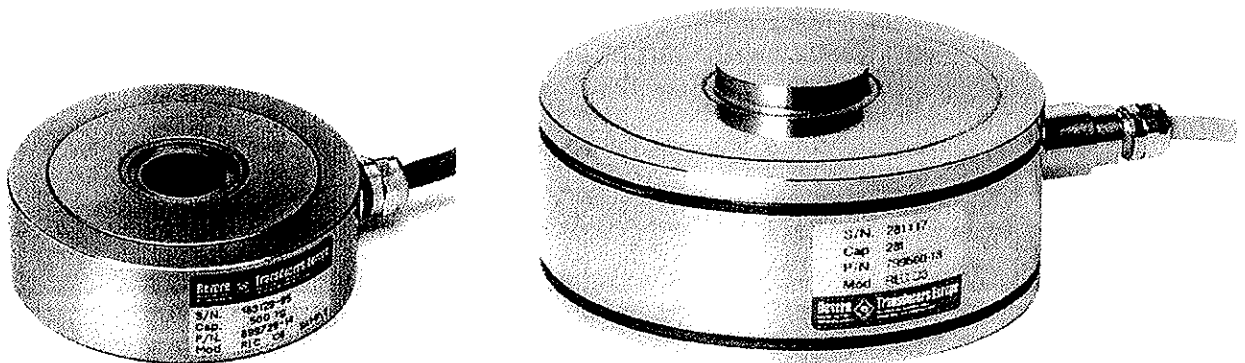
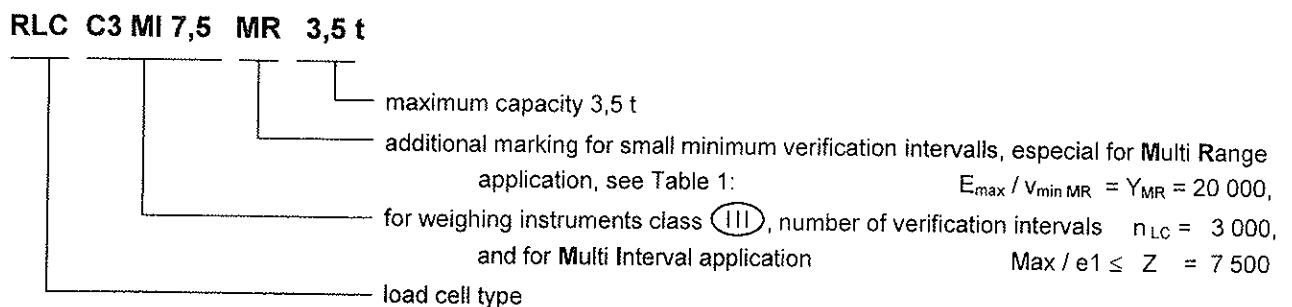
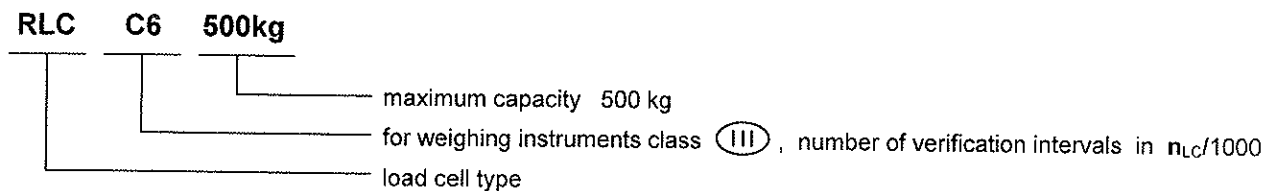

Figure 1: Load cells type RLC C6 0,5t and type RLC C3 28t

Examples of a complete type designation on the identification plate:



4. Documentation

The test results and the following drawings are kept at the PTB:

drawing No : 12-009192, ..193, ..254, ..272 und ..252 load cell body
899730 Bl.1 u. 2 wiring, cable input and dimensions

Anlage zum Prüfschein

Annex to test certificate

vom 07.04.2000, Prüfscheinnummer: D09-97.18 Rev. 2

dated 07.04.2000, test certificate number: D09-97.18 Rev. 2

Seite 4 von 5 Seiten

Page 4 of 5 pages

5. Further information

- Scope of Revision 2

Extension of the maximum capacities by 0,06t and 0,13t as well as 13t, 28t and 60t, change of the layout of the test certificate.

- Validity of this test certificate

Manufacturing process, material and sealings of the produced load cells have to be in accordance with the tested specimen; essential changes are only allowed with the permission of the PTB.

- Data sheet

The data for deviation from non linearity, hysteresis and temperature effect on rated output are typical values. The sum of these data meets the requirements according to OIML R60.

The technical data and the dimensions are given in the annex and have to be complied with.

According to DIN/EN 45501 Nr. 4.12 the load cells are applicable in weighing instruments class

III and IIII .

6. Dimensions and data sheet

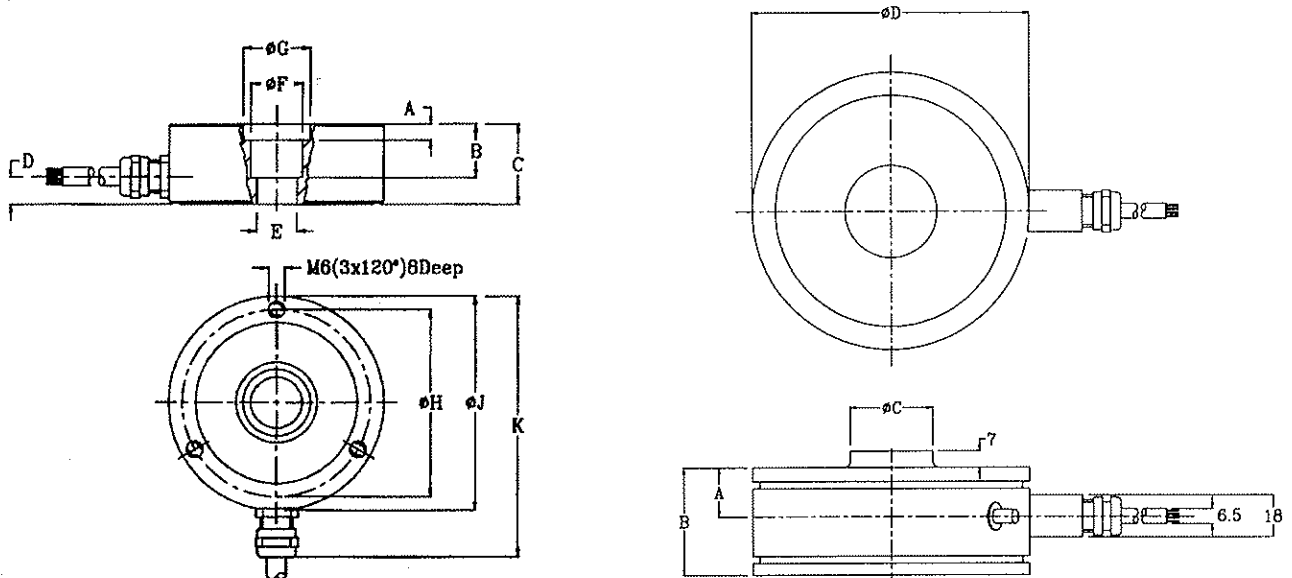

K	97	97.5	97.5	112.5	135
ØJ	Ø63	Ø80	Ø80	Ø85	Ø95
ØH	Ø55.5	Ø70	Ø70	Ø83	-
ØG	-	Ø25	Ø25	-	-
ØF	Ø15.1	Ø19	Ø19	Ø29.1	Ø29.1
E	Ø3.2	M10	Ø15 H7	Ø24.9	Ø24.9
D	15	9.5	8.5	10	20
C	22	25	30	35	35
B	16	15	20	14.8	14.8
A	-	1.0	6.0	-	-
CAPACITY	0.06t & 0.13t	0.25t, 0.5t & 1t	2t, 3.5t & 5t	10t	13

D	Ø120	Ø140
C	Ø35.9	Ø47.9
B	46	62
A	21	28
CAPACITY	28t	60t

Physikalisch-Technische Bundesanstalt

Anlage zum Prüfschein

Annex to test certificate

vom 07.04.2000, Prüfscheinnummer: D09-97.18 Rev. 2

Seite 5 von 5 Seiten

dated 07.04.2000, test certificate number: D09-97.18 Rev. 2

Page 5 of 5 pages

SPECIFICATIONS LOAD CELL TYPE RLC

Specification / description	Symbol	Unit	RLC									
			C1	C2	C3	C3M16	C3M17,5	C4	C5	C6		
Accuracy Class acc. to OIML R60												
Maximum Number of Divisions	n_{max}		1000	2000	3000	3000	3000	4000	5000	6000		
Standard Capacities	E_{max}	t	0.06 / 0.13 / 0.25 / 0.5 / 1 / 2 3.5 / 5 / 10 / 13 / 28 / 60 ¹⁾			0.06 + 10		0.5 (0.75%) 1 / 2 / 3.5 / 5				
Minimum Deadload	E_{min}	% E_{max}	0 (4% for 250 kg version)									
Temperature Effect on Sensitivity	TKc	ppm/K	< 20	< 10	< 10	< 10	< 10	< 8	< 6	< 5		
Temperature Effect on MDLO	TK0	ppm/K	< 28	< 19	< 14	< 14	< 14	< 14	< 9	< 9		
Minimum Verification Interval	V_{min} (Y)		$E_{max}/5000$	$E_{max}/7500$	$E_{max}/10000$	$E_{max}/10000$	$E_{max}/10000$	$E_{max}/10000$	$E_{max}/15000$	$E_{max}/15000$		
Temperature Effect on MDLO (MR)	TK0 (MR)	ppm/K	< 14	< 9	< 7 (9) ¹⁾	< 7	< 7	< 7	< 5,5	< 5		
Minimum Verification Interval (MR)	V_{min} (Y)		$E_{max}/10000$	$E_{max}/15000$	$E_{max}/20000$	$E_{max}/20000$	$E_{max}/20000$	$E_{max}/20000$	$E_{max}/25000$	$E_{max}/28000$		
Deadload output Return	DR (Z)		--	--	--	$\frac{1}{2}E_{max}/6000$	$\frac{1}{2}E_{max}/7500$	--	--	--		
Creep 0 - 30 min. Creep 20 - 30 min.		ppm	< 490 < 105	< 245 < 53	< 245 < 53	< 123 < 26	< 98 < 21	< 184 < 39	< 147 < 32	< 123 < 26		
Recovery After 30 min. Full Load		ppm	< 500	< 250	< 167	< 83	< 68	< 125	< 100	< 83		
Hysteresis		ppm	< 500	< 250	< 167	< 83	< 68	< 125	< 100	< 83		
Combined Error		ppm	< 470	< 230	< 230	< 230	< 230	< 173	< 140	< 115		
Rated Output		mV/V	2.00 ± 0.1 (1.75 for 250 kg version)									
Zero Balance		mV/V	0.00 ± 0.02 (±0.03 for 250 kg version)									
Input Resistance	R_i	Ω	1110 ± 50									
Output Resistance	R_o	Ω	1025 ± 25									
Tolerance on Current Calibration			± 0.02									
Insulation Resistance	R_s	G Ω	> 5									
Excitation Voltage		V	5 to 15									
Maximum Excitation Voltage		V	30									
Reference Temperature		°C	21									
Compensated Temperature Range		°C	-10 to +40									
Operating Temperature Range		°C	-30 to +70									
Storage Temperature Range		°C	-50 to +80									
Deflection		mm	0.10 ± 0.02									
Safe Overload		% E_{max}	150									
Maximum Sideload		% E_{max}	100									
Element Material			Stainless Steel DIN 1.4542									
Sealing (DIN 40.50 / EN 60.529)			IP66/68									

Note: "temperature Effect on Sensitivity" and "Combined Error" are combined in such a way that the load cells meet the tolerance envelope of R60.
¹⁾ for C3 MR 28t and 60t TC0 < 9 ppm/K, Y=15000

Hinweise

Prüfscheine ohne Unterschrift und Siegel haben keine Gültigkeit. Dieser Prüfschein darf nur unverändert weiterverbreitet werden. Auszüge bedürfen der Genehmigung der Physikalisch-Technischen Bundesanstalt.

Notes

Test certificates without signature are not valid. This test certificate may not be reproduced other than in full. Extracts may be taken only with the permission of the Physikalisch-Technische Bundesanstalt.

Physikalisch-Technische Bundesanstalt

Bundesallee 100
D-38116 Braunschweig

Abbestraße 2-12
D-10587 Berlin

Fürstenwalder Damm 388
D-12587 Berlin