

## Single Point Aluminum Load Cell



### FEATURES

- Capacity range: 3 - 200kg
- Only 22 mm high
- Aluminum construction
- Single point 350 x 350mm platform
- IP66 protection
- OIML R60 and NTEP approved

### OPTIONAL FEATURES

- EEx ia IIC T4 - ATEX hazardous area approval
- FM approval
- Capacities 50-200kg available with non-approved specifications

### DESCRIPTION

Model 1022 is a low profile single point load cell designed for direct mounting in low cost weighing platforms.

Its small physical size, combined with high accuracy and aluminum construction, makes this low cost load cell ideally suited for retail, bench and counting scales.

Using 1022 load cells simplifies scale construction, which results in significant parts and labor savings.

Available in a range of capacities, from 3 to 200kg and approved to OIML R60 (4000d) or NTEP (5000d, single). Environmental protection to IP66 is provided as standard. For hazardous environments, ATEX EEx ia IIC T4 approved versions are available.

### APPLICATIONS

- Bench scales
- Counting scales
- Grocery scales

### OUTLINE DIMENSIONS in millimeters

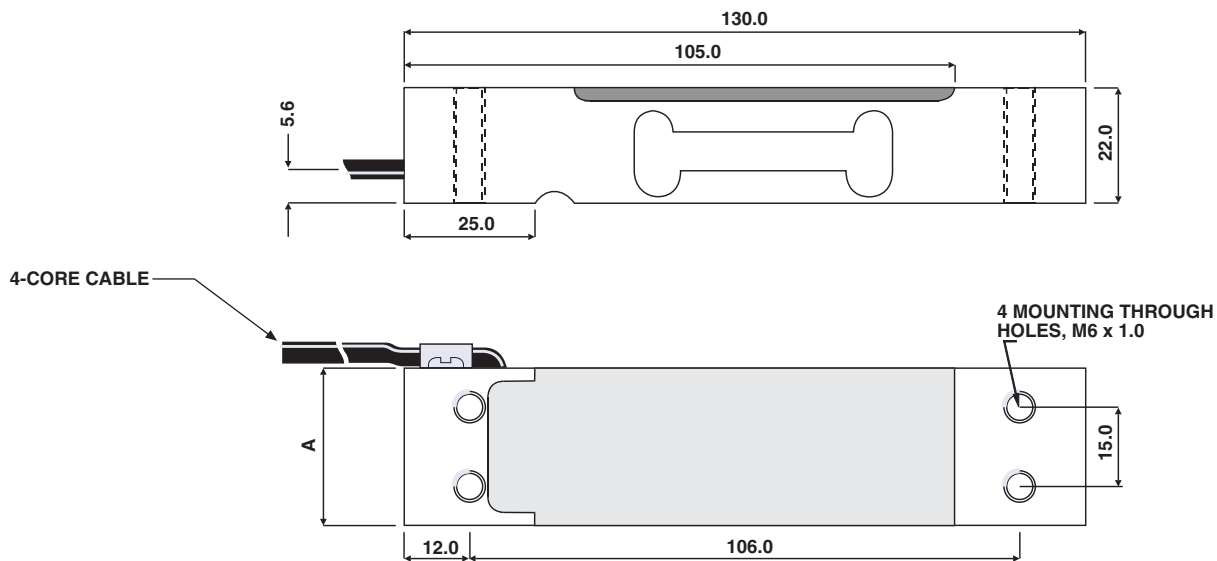

CAPACITY	A
3, 5, 7kg	25.4
10, 15, 20, 30kg	30.0
35 - 200kg	40.0



**SPECIFICATIONS**

PARAMETER	VALUE			UNIT
Rated capacity-R.C. ( $E_{max}$ )	3, 5, 7, 10, 15, 20, 30, 35, 50, 100, 150, 200****			kg
NTEP/OIML Accuracy class	NTEP	Non-Approved	C3*	
Maximum no. of intervals (n)	5000 single**	1000	3000***	
$Y = E_{max}/N_{min}$	15000	3333	10000	Maximum available
Rated output-R.O.	2.0			mV/V
Rated output tolerance	0.2			±mV/V
Zero balance	0.2			+mV/V
Zero Return, 30 min.	0.0330	0.0300	0.0170	±% of applied load
Total Error (per OIML R60)	0.0200	0.0500	0.0200	±% of rated output
Temperature effect on zero	0.0023	0.0100	0.0023	±% of rated output/°C
Temperature effect on output	0.0010	0.0030	0.0010	±% of applied load/°C
Eccentric loading error	0.0057	0.0085	0.0057	±% of rated load/cm
Temperature range, compensated	-10 to +40			°C
Temperature range, safe	-20 to +70			°C
Maximum safe central overload	150			% of R.C.
Ultimate central overload	300			% of R.C.
Excitation, recommended	10			Vdc or Vac rms
Excitation, maximum	15			Vdc or Vac rms
Input impedance	415±15			Ohms
Output impedance	350±3			Ohms
Insulation resistance	>2000			Mega-Ohms
Cable length	0.5			m
Cable type	4 wire, PVC, single floating screen			Standard
Construction	Aluminum			
Environmental protection	IP66			
Platform size (max)	350 x 350			mm
Recommended torque	Up to 30kg: 7.0 35kg & up: 10.0			N*m

\* 50% utilization

\*\* Also available at 50% utilization

\*\*\* Also available in 4000 divisions in non symmetric version

\*\*\*\* 50-200kg are not approved by OIML and NTEP

WIRING SCHEMATIC DIAGRAM  
(UNBALANCED BRIDGE CONFIGURATION)

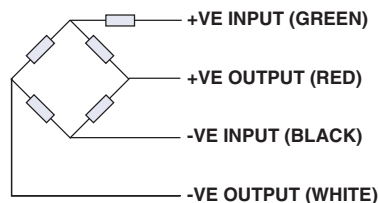



## Notice

Specifications of the products displayed herein are subject to change without notice. Vishay Intertechnology, Inc., or anyone on its behalf, assumes no responsibility or liability for any errors or inaccuracies.

Information contained herein is intended to provide a product description only. No license, express or implied, by estoppel or otherwise, to any intellectual property rights is granted by this document. Except as provided in Vishay's terms and conditions of sale for such products, Vishay assumes no liability whatsoever, and disclaims any express or implied warranty, relating to sale and/or use of Vishay products including liability or warranties relating to fitness for a particular purpose, merchantability, or infringement of any patent, copyright, or other intellectual property right.

The products shown herein are not designed for use in medical, life-saving, or life-sustaining applications. Customers using or selling these products for use in such applications do so at their own risk and agree to fully indemnify Vishay for any damages resulting from such improper use or sale.